

# ML15 PA Horn Loudspeaker

The ML15 15W PA loudspeaker features a robust, fire retardant, IP66 & IP67 housing; suitable for harsh environments with high ambient noise levels.

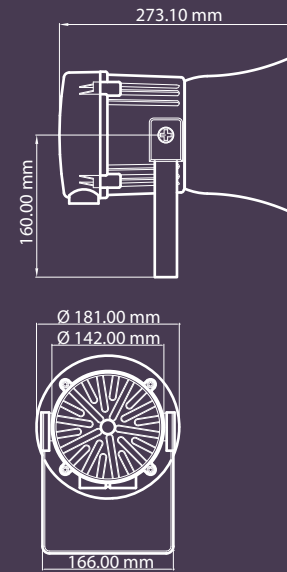

### Specification:

|                        |  |
|------------------------|--|
| SPL:                   | 108dB +/-3dB @ 1w @ 1m - Pink noise<br>118dB +/-3dB @ 15w (rated power) @ 1m     |
| Rated power:           | 15 Watts RMS   |
| 70v line tapplings:    | 15w / 7.5w / 3w / 1w (z=336.67 Ohms / 653.33 Ohms / 1.6kOhms / 4.9kOhms)         |
| 100v line tapplings:   | 15w / 7.5w / 3w / 1w (z=666.87 Ohms / 1.34kOhms / 3.34kOhms / 10kOhms)           |
| Low impedance:         | 8 Ohm or 16 Ohm  |
| Dispersion:            | 120° @ 1kHz & 32° @ 4kHz   |
| Frequency range:       | 400Hz to 8000 Hz   |
| DC Line monitoring:    | 2.2uF Capacitor (Transformer version)<br>470uF Capacitor (Low impedance version) |
| Ingress protection:    | IP66 & IP67 (Third party tested)   |
| Housing material:      | High impact UL94 V0 & 5VA FR ABS   |
| Colour:                | Grey (RAL7038)   |
| Cable entries:         | 2 x M20 supplied with 1 blanking plug  |
| Terminals:             | 0.5 to 4.0mm <sup>2</sup> cables.  |
| Operating temperature: | -25 to +55°C   |
| Storage temperature:   | -40 to +70°C   |
| Relative humidity:     | 90% at 20°C.   |
| Weight :               | 70/100V line: 2.60kg<br>Low impedance: 2.20kg                                    |

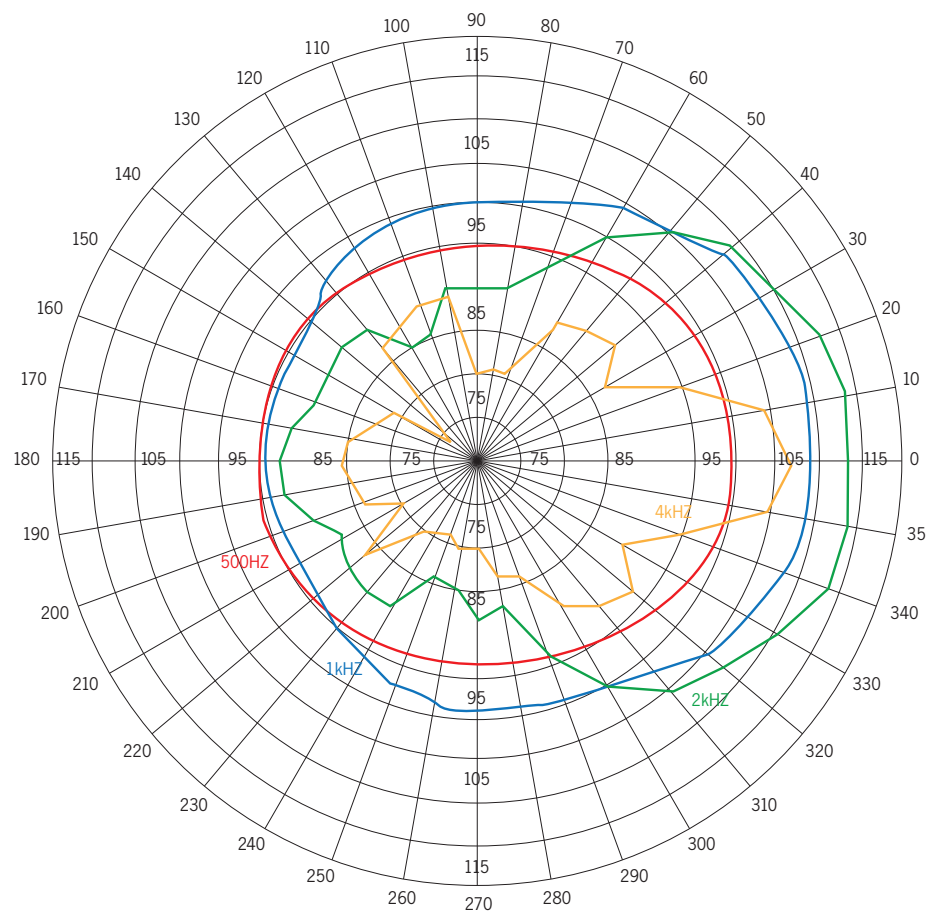

### Part codes:

| Version:  | Part code: |
|-----------|------------|
| 100V Line | ML15W100VG |
| 70V Line  | ML15W70VG  |
| 16 Ohm    | ML15W16RG  |
| 8 Ohm     | ML15W8RG   |

### Features:

- Continuously rated.
- Large termination area.
- Stainless steel fixings.
- Ratchet adjustable stainless steel 'U' bracket for 360° positioning.
- Duplicate cable terminations (in & out for daisy-chain installations).
- Tropicalisation available on request.

### Approvals:

- UKOOA/PFEER compliant alarm tones.
- GOST-R approved. Cert: POCC GB-JB05-B02228

\*SPL data +/-3dB(A). Measured at optimum voltage.

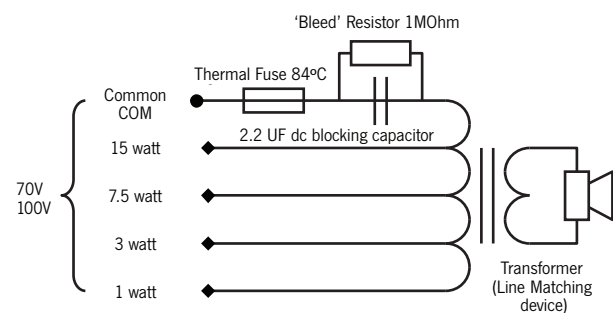

Also available as the MCL15-05 15W PA Loudspeaker with Xenon beacon.

